

## ASYO Group Technologies

### BLG 01 Basic Lift Gate



Pass-through

#### Description

The Basic Lift Gate is a transport conveyor that can create an opening in a production line. The conveyor segment can be hinged open by the operator and has to be closed manually again. The opening is 845 mm wide. The powder coated steel frame ensures process stability and excellent durability.

#### Features

- \_ Start / Stop push button
- \_ Walk through
- \_ Anti-static conveyor belts
- \_ SMEMA Interface

#### Options

- \_ Transport height 850 mm  $\pm$  50 mm
- \_ Electrical width adjustment
- \_ Adjustable handover speed
- \_ Inspection function 0/1
- \_ Pneumatic lock

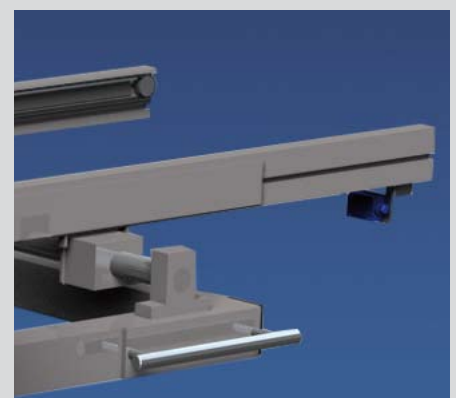
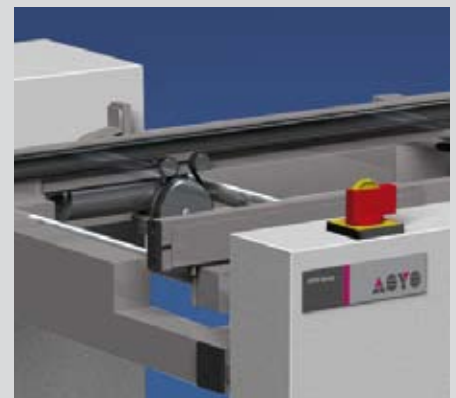

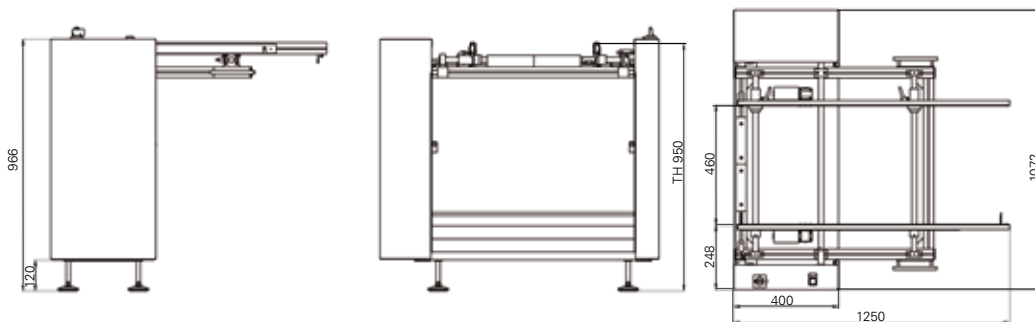

## BLG 01 Basic Lift Gate

ASYS Handling Equipment - Basic Series

# Basic Series

### BLG 01

#### Machine Configuration

Transport height	950 mm ± 50 mm
Max. transport width	<b>460 mm</b>
Pass through width	845 mm
Interface	SMEMA
Transfer direction	from left to right
Operating side	Front of the machine
Fixed rail	Front of the machine

#### Panel Dimensions

Panel length	50 to 460 mm
Panel width	50 to 460 mm
Panel thickness	0.8 to 4.5 mm
Component clearance	± 40 mm
Panel weight	to 3 kg

#### Installation Requirements

Power supply	230 V / 115 V, 50 / 60 Hz, ± 10%
Power supply system	L1 + N + PE
Power consumption	0,14 kW

#### Machine Description

Length x Width x Height	1250 x 1072 x 966 mm
Color <sup>a)</sup>	Basic Light
Noise Level	< 75 dB

#### Upgrades

Control panel T70  
 Additional interface protocol  
 Automatic width adjustment <sup>b)</sup>  
 Machine networking via IC Net

a) RAL colors at a surcharge  
 b) only with control panel T70

www.asys-group.com

ASYS Automatisierungssysteme GmbH  
 Benzstraße 10, D-89160 Dornstadt  
 Germany  
 Tel. (+49) 7348 9855 0  
 Fax (+49) 7348 9855 91  
 info@asys.de

ASYS Group Asia Pte Ltd  
 30 Shaw Road #01-02/03  
 Singapore 367957  
 Tel. (+65) 6280 8887  
 Fax (+65) 6858 5005  
 sales@asysgroup-asia.com

ASYS Inc.  
 140 Satellite Boulevard NE  
 Suite B1, Suwanee  
 GA 30024 USA  
 Tel. (+1) 770 246 9706  
 Fax (+1) 770 246 9866  
 info@asys-group.com

Subject to change without notice.  
 Some general descriptions and performance characteristics may not be applicable to all products. Technical specifications are subject to change without notice. Only features and technical data provided in purchasing contract are legally binding.

Printed in Germany