

### Description

The Basic Turn Table is typically located in a SMD line which requires a 90 degree turn or a sorting feature. The conveyor segment is mounted on an pneumatic turn table and PCBs are routed based upon the run mode or an external signal. Possible run modes are pass through, load, offload and sort. The powder coated steel frame ensures process stability and excellent durability.

### Features

- \_ Turn
- \_ Start / Stop push button
- \_ Anti-static conveyor belts
- \_ SMEMA Interface

### Options

- \_ Transport height 850 mm  $\pm$  50 mm
- \_ Electrical width adjustment
- \_ Inlet conveyor 530 mm <sup>c) d)</sup>
- \_ Outlet conveyor 530 mm <sup>c) d)</sup>

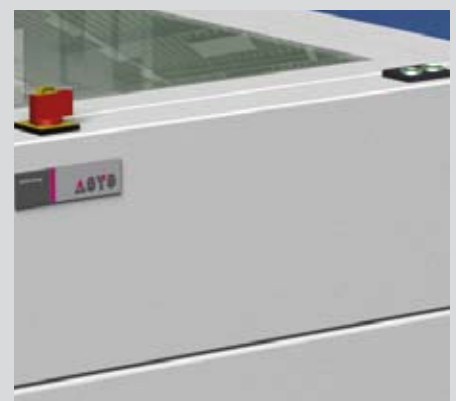

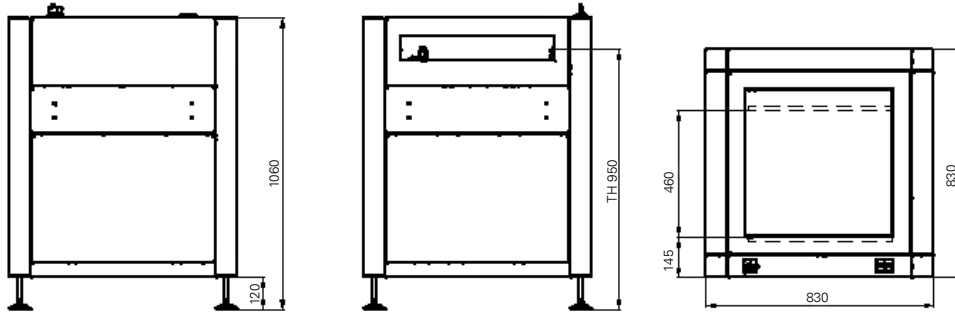

## BTT 01 Basic Turn Table

ASYS Handling Equipment - Basic Series

# Basic Series

### BTT 01

#### Machine Configuration

Transport height	950 mm ± 50 mm
Max. transport width	<b>460 mm</b>
Interface	SMEMA
Transfer direction	from left to right
Operating side	Front of the machine
Fixed rail	Front of the machine

The adjacent upstream and downstream modules must have screwed-on covers.

#### Panel Dimensions

Panel length	50 to 460 mm
Panel width	50 to 460 mm
Panel thickness	0.8 to 4.5 mm
Component clearance	± 40 mm
Panel weight	to 3 kg

#### Installation Requirements

Power supply	230 V / 115 V, 50 / 60 Hz, ± 10%
Power supply system	L1 + N + PE
Power consumption	0,16 kW
Air supply	6 bar
Air consumption	15 NI/min

#### Machine Description

Length x Width x Height	830 x 830 x 1060 mm
Color <sup>a)</sup>	Basic Light
Noise Level	< 75 dB

#### Upgrades

Control panel T70  
 Additional interface protocol  
 Automatic width adjustment <sup>b)</sup>  
 Pass through with load, offload function  
 Good/Bad sorting  
 Machine networking via IC Net

a) RAL colors at a surcharge

b) only with control panel T70

c) Connection of maximum 2 additional conveyors.

d) The conveyors must have screwed-on covers

[www.asys-group.com](http://www.asys-group.com)

ASYS Automatisierungssysteme GmbH  
 Benzstraße 10, D-89160 Dornstadt  
 Germany  
 Tel. (+49) 7348 9855 0  
 Fax (+49) 7348 9855 91  
 info@asy.de

ASYS Group Asia Pte Ltd  
 30 Shaw Road #01-02/03  
 Singapore 367957  
 Tel. (+65) 6280 8887  
 Fax (+65) 6858 5005  
 sales@asygroup-asia.com

ASYS Inc.  
 140 Satellite Boulevard NE  
 Suite B1, Suwanee  
 GA 30024 USA  
 Tel. (+1) 770 246 9706  
 Fax (+1) 770 246 9866  
 info@asy-group.com

Subject to change without notice.

Some general descriptions and performance characteristics may not be applicable to all products. Technical specifications are subject to change without notice. Only features and technical data provided in purchasing contract are legally binding.

Printed in Germany